

Closed-loop Robust Identification Using the Indirect Approach

Rimantas PUPEIKIS

*Institute of Mathematics and Informatics, Vilnius Gediminas Technical University
Akademijos 4, 2000 Vilnius, Lithuania
e-mail: pupeikis@ktl.mii.lt*

Received: June 2000

Abstract. In the previous paper (Pupeikis, 2000) the problem of closed-loop robust identification using the direct approach in the presence of outliers in observations have been considered. The aim of the given paper is a development of the indirect approach used for the estimation of parameters of a closed-loop discrete-time dynamic system in the case of additive correlated noise with outliers contaminated uniformly in it. To calculate current M -estimates of unknown parameters of such a system by means of processing input and noisy output observations, obtained from closed-loop experiments, the recursive robust technique based on an ordinary recursive least square (RLS) algorithm is applied here. The results of numerical simulation of closed-loop system (Fig. 3) by computer (Figs. 4–7) are given.

Key words: adaptive system, closed-loop, direct approach, identification, observations, outliers.

1. Introduction

Adaptive control systems act while the properties of controlled processes and signals are varying in time. The quality of performance of an adaptive control system strongly depends on the accuracy of a tuned process model and on the closed-loop identification technique to be applied. Some interesting results on optimal experiment design for the case that no explicit constraints are imposed on the input or output variance and the misfit in both the dynamics model and the noise model is penalized are given in (Forsell and Ljung, 2000). There are several ways to identify the open-loop characteristics (Gustavsson *et al.*, 1974). One can divide these identification methods into three groups (Isermann, 1982): a direct approach, an indirect approach and an joint input-output approach. The direct approach ignores the feedback and identifies the open-loop system using only input-output observations, obtained from closed-loop experiments. It is known (Forsell and Ljung, 1999) that the direct approach gives consistency and optimal accuracy in spite of the feedback when the noise and the model of the dynamic system contain a true description. Using the indirect approach we identify some sensitivity function of the closed-loop system and then determine the estimates of the parameters of the open-loop system if the controller parameters are known. Here the prediction error techniques for the estimation of unknown parameters of the sensitivity function are usually used (Gustavsson *et al.*, 2000; Ljung, 1978; Söderström *et al.*, 1991). On the other hand, if the

output is corrupted by an additive noise containing outliers, then the ordinary prediction error methods applied to identify even unknown parameters of an open-loop dynamic system, described by the difference equation, could be of little use. Therefore, in such a case there arise a problem of the closed-loop robust identification by processing noisy observations. It can be solved applying respective recursive prediction error techniques, which can be easily suited to the parameter estimation of dynamic systems in the case of outliers in observations to be processed (Novovičova, 1987; Pupeikis, 1994).

2. The Statement of the Problem

Assume that the control system to be observed is causal, linear and time-invariant (LTI) with one output $\{y(k)\}$, $k = 1, 2, \dots$, and one input $\{u(k)\}$, $k = 1, 2, \dots$, and given by the equation

$$\begin{aligned} y(k) &= G_0(q, \theta)u(k) + v(k), \\ v(k) &= H_0(q, \varphi)\xi(k), \end{aligned} \quad (1)$$

which consists of two parts: a process model $G_0(q, \theta)$ and a noise one $H_0(q, \varphi)$.

Here θ, φ are unknown parameter vectors, q is the time-shift operator (i.e., $q^{-1}u(k) = u(k-1)$), the initial signal $\{\xi(k)\}$, $k = 1, 2, \dots$, used to generate unmeasurable noise $\{v(k)\}$, $k = 1, 2, \dots$, is assumed to be statistically independent and stationary with

$$\begin{aligned} E\{\xi(k)\} &= 0, \\ E\{\xi(k)\xi(k+\tau)\} &= \sigma_\xi^2\delta(\tau). \end{aligned} \quad (2)$$

$E\{\cdot\}$ is a mean value, σ_ξ^2 is a variance, $\delta(\tau)$ is the Kronecker delta function, $H_0(q, \varphi)$ is an inversely stable, monic filter.

The input $\{u(k)\}$, $k = 1, 2, \dots, N$, is given by

$$u(k) = \Psi(k, y^k, u^{k-1}, r(k)), \quad (3)$$

where $y^k = [y(1), \dots, y(k)]$, $u^{k-1} = [u(1), \dots, u(k-1)]$. The reference signal $\{r(k)\}$, $k = 1, 2, \dots$, is a quasi-stationary signal, independent of the stochastic disturbance $\{v(k)\}$, $k = 1, 2, \dots$, and Ψ is a given deterministic function such that the closed-loop system (1), (2) with the controller $G_R(q, \alpha)$ (see Fig. 1), which is designed for disturbance $\{v(k)\}$, $k = 1, 2, \dots$, by minimizing a quadratic performance function

$$J = \lim_{N \rightarrow \infty} E \left\{ \frac{1}{N} \sum_{k=0}^{N-1} y^2(k) + \rho u^2(k) \right\}, \quad (4)$$

is exponentially stable (Forsell and Ljung, 1999). Here α is the known parameter vector of the controller, the factor $0 < \rho \leq 1$.

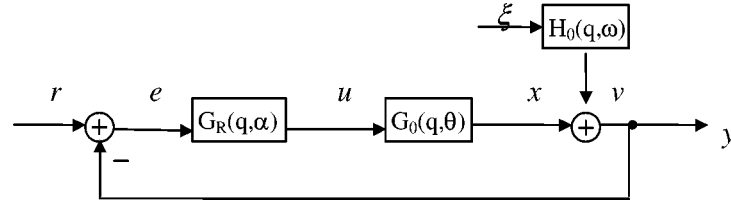

Fig. 1. A closed-loop system to be observed.

The basis of identification is the data set

$$Z^N = \{r(1), \dots, r(N), y(1), \dots, y(N)\}, \quad (5)$$

consisting of measured observations of the reference signal $\{r(k)\}$ and output $\{y(k)\}$, $k = 1, 2, \dots, N$, signals. The aim of the given paper is to estimate the parameter vector θ of the system (1), (2) using the indirect approach, when assumption (2) is not satisfied because of occasionally appearing outliers in an unmeasurable noise signal $\{v(k)\}$, $k = 1, 2, \dots$, acting on the output of the closed-loop system (Fig. 1).

3. The Indirect Approach for the Closed-loop System

The indirect approach consists of two steps: first the closed-loop system is identified, then the model of the open-loop system is determined. Here we start to obtain the closed-loop system.

The input signal $\{u(k)\}$ and the output signal $\{y(k)\}$, $k = 1, 2, \dots$, are determined according to

$$u(k) = [r(k) - y(k)] G_R(q, \alpha), \quad (6)$$

$$y(k) = G_0(q, \theta)u(k) + H_0(q, \varphi)\xi(k), \quad (7)$$

respectively. By combining (6) and (7) we obtain the closed-loop relations

$$y(k) = \Phi_0(q, \beta)G_0(q, \theta)G_R(q, \alpha)r(k) + \Phi_0(q, \beta)H_0(q, \varphi)\xi(k), \quad (8)$$

$$u(k) = W_0(q, \beta)G_R(q, \alpha)r(k) - W_0(q, \beta)G_0(q, \theta)H_0(q, \varphi)\xi(k), \quad (9)$$

with the output and the input sensitivity functions

$$\Phi_0(q, \beta) = [1 + G_0(q, \theta)G_R(q, \alpha)]^{-1}, \quad (10)$$

$$W_0(q, \beta) = [1 + G_R(q, \alpha)G_0(q, \theta)]^{-1}, \quad (11)$$

correspondingly. Now alike to (Forsell and Ljung, 1999) we also introduce

$$G_0^c(q, \omega) = \Phi_0(q, \beta)G_0(q, \theta)G_R(q, \alpha) \quad \text{and} \quad H_0^c(q, \varphi) = \Phi_0(q, \beta)H_0(q, \varphi). \quad (12)$$

So we can rewrite the relation (8) of the closed-loop system as

$$y(k) = G_0^c(q, \omega)r(k) + H_0^c(q, \varphi)\xi(k). \quad (13)$$

It follows from (13) that the function $G_0^c(q, \omega)$ could be determined in an open-loop way, because $\{y(k)\}$, $k = 1, 2, \dots$ and $\{r(k)\}$, $k = 1, 2, \dots$ are observed and moreover $\{r(k)\}$ and $\{\xi(k)\}$, $k = 1, 2, \dots$, are mutually independent. If the controller $G_R(q, \alpha)$ is known and $\{r(k)\}$, $k = 1, 2, \dots$, is measurable, we can identify the transfer function $G_0^c(q, \omega)$ of the closed-loop system (13) using the prediction error method with a model

$$y(k) = G^c(q, \omega)r(k) + H_*(q, \varphi)e(k) \quad (14)$$

according to (Forsell and Ljung, 1999), where $G^c(q, \omega)$ corresponds to $G_0^c(q, \omega)$ and $H_0^c(q, \varphi)$ to $H_*(q, \varphi)$. Then we compute an estimate $\widehat{G}_N(q, \theta)$ of the open-loop system $G_0(q, \theta)$ by solving the equation

$$\widehat{G}_N^c(q, \omega) = [1 + \widehat{G}_N(q, \theta)G_R(q, \alpha)]^{-1} \widehat{G}_N(q, \theta)G_R(q, \alpha). \quad (15)$$

Here $G^c(q, \omega)$ is a parametrized model of the closed-loop system, $\widehat{G}_N^c(q, \omega)$, $\widehat{G}_N(q, \theta)$ are the estimates of the closed-loop and open-loop systems, respectively.

The exact solution is:

$$\widehat{G}_N(q, \theta) = [1 - \widehat{G}_N^c(q, \omega)]^{-1} [G_R(q, \alpha)]^{-1} \widehat{G}_N^c(q, \omega). \quad (16)$$

The order of $\widehat{G}_N(q, \theta)$ is equal to the sum of the orders of $\widehat{G}_N^c(q, \omega)$ and $G_R(q, \alpha)$. The estimate of θ could be found by solving some overdetermined system of equations in many ways. As is noted in (Forsell and Ljung, 1999), a particularly simple and attractive approach is to let the parameters θ relate to properties of the open-loop system $G_0(q, \theta)$ so that in the first step we should parametrize $G_0^c(q, \omega)$ as

$$G_0^c(q, \omega) = [1 + G_0(q, \theta)G_R(q, \alpha)]^{-1} G_0(q, \theta)G_R(q, \alpha). \quad (17)$$

The parametrization of $G_0^c(q, \omega)$ is important for numeric and algebraic reasons, but it does not affect the asymptotic statistical properties of $\widehat{G}_N^c(q, \omega)$ (Forsell and Ljung, 1999).

To obtain $\widehat{G}_N^c(q, \theta)$ we use a model (14) and the prediction error method, which minimize some prediction error criterion in order to get the parameter estimates. The prediction error is

$$e(k/\theta, \omega, \varphi) = y(k) - \widehat{y}(k/\omega, \varphi) = H_*^{-1}(q, \varphi)(y(k) - G^c(q, \omega)r(k)), \quad (18)$$

where the one-step-ahead predictor for the model structure (13) is

$$\widehat{y}(k/\omega, \varphi) = H_*^{-1}(q, \varphi)G^c(q, \omega)r(k) + (1 - H_*^{-1}(q, \varphi))y(k). \quad (19)$$

Given the model (14) and measured data $\{y(k)\}$, $k = 1, 2, \dots$, and $\{r(k)\}$, $k = 1, 2, \dots$, we determine the prediction error estimate using formulas:

$$\begin{aligned} \hat{\omega}_N &= \arg \min_{\omega \in D_M} V_N(\theta, \omega, \varphi, \eta, Z^N), \\ V_N(\theta, \omega, \varphi, \eta, Z^N) &= \frac{1}{N} \sum_{t=1}^N e_p^T(k/\theta, \omega, \varphi, \eta) \Lambda^{-1} e_p(k/\theta, \omega, \varphi, \eta), \\ e_p(k/\theta, \omega, \varphi, \eta) &= L(q, \eta) e(k/\theta, \omega, \varphi, \eta) \\ &= L(q, \eta) H_*^{-1}(q, \varphi) [y(k) - G^c(q, \omega) r(k)]. \end{aligned} \quad (20)$$

Here Λ is a symmetric, positive definite weighting matrix and $L(q, \eta)$ is a monic prefilter that can be used to enhance certain frequency regions, Z^N is of the form (5).

The indirect approach allows us to apply the well known prediction error techniques directly to input $\{r(k)\}$, $k = 1, 2, \dots$ and output $\{y(k)\}$, $k = 1, 2, \dots$, observations, used for determination of the parameters of closed-loop system. The block scheme of such procedure is shown in Fig. 2. The parameter vector ω can be determined by the ordinary least squares method (LS) by minimizing the sum of the form

$$\sum_{t=1}^N [y(t) - z^T(t)\omega]^2 = \min! \quad (21)$$

where $z^T(\cdot)$ is a vector of observations of the reference signal $\{r(k)\}$, $k = 1, 2, \dots$ and noisy output $\{y(k)\}$, $k = 1, 2, \dots, N$.

Thus, the ordinary open-loop prediction error method is based on the RLS of the form

$$\omega(k) = \omega(k-1) + \frac{P(k-1)z(k-1)}{1 + z^T(k)P(k-1)z(k)} [y(k) - z^T(k)\omega(k-1)], \quad (22)$$

$$P(k) = P(k-1) - \frac{P(k-1)z(k)z^T(k)P(k-1)}{1 + z^T(k)P(k-1)z(k)}, \quad (23)$$

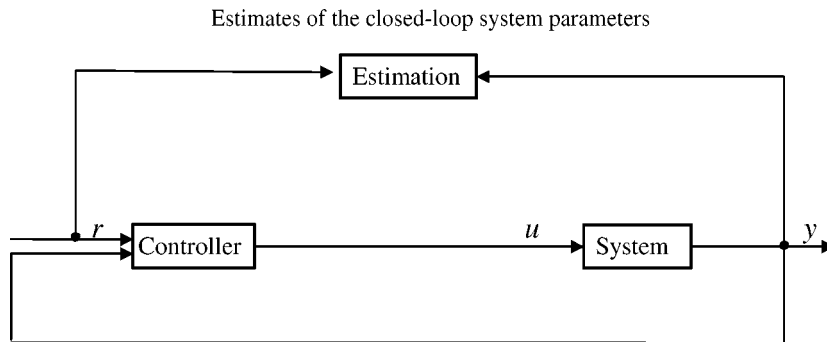

Fig. 2. A closed-loop system with an estimation procedure.

with the vector of observations

$$z^T(k) = (r(k-1), \dots, r(k-m), y(k-1), \dots, y(k-m)), \quad (24)$$

and some initial values of the vector $\omega(0)$ and of the matrix $P(0)$, when $G^c(q, \omega)$ is the system transfer function of the form

$$G^c(q, \omega) = \frac{C(q, b)}{D(q, a)} = \frac{c_1 q^{-1} + c_2 q^{-2} + \dots + c_m q^{-m}}{1 + d_1 q^{-1} + \dots + d_m q^{-m}}. \quad (25)$$

Here

$$\omega^T(k) = (c_1(k), c_2(k), \dots, c_m(k), d_1(k), d_2(k), \dots, d_m(k)) \quad (26)$$

is an estimate of the parameter vector

$$\omega^T = (c_1, c_2, \dots, c_m, d_1, d_2, \dots, d_m). \quad (27)$$

So, by the determining the closed-loop system we have transformed the closed-loop identification problem into an “open-loop” one, since $\{r(k)\}$ and $\{\xi(k)\}$, $k = 1, 2, \dots$ are mutually independent. In such a case any technique, that acts in open-loop could be used in order to obtain the estimates of the parameters (27) of the closed-loop system (Fig. 1).

4. The Indirect Approach in a Presence of Outliers in Observations

Assume now that the white noise $\{\xi(k)\}$, $k = 1, 2, \dots$, really is a sequence of independent identically distributed variables with an ε -contaminated distribution of the form

$$p(\xi(k)) = (1 - \varepsilon)N(0, \sigma_\mu^2) + \varepsilon N(0, \sigma_\zeta^2) \quad (28)$$

and the variance

$$\sigma_\xi^2 = (1 - \varepsilon)\sigma_\mu^2 + \varepsilon\sigma_\zeta^2; \quad (29)$$

$p(\xi(k))$ is the probability density distribution of the sequence $\{\xi(k)\}$, $k = 1, 2, \dots$;

$$\xi(k) = (1 - \gamma_k)\mu_k + \gamma_k\zeta_k \quad (30)$$

is the value of the sequence $\{\xi(k)\}$, $k = 1, 2, \dots$ at a time moment k ; γ is a random variable, taking values 0 or 1 with probabilities $p(\gamma_k = 0) = 1 - \varepsilon$, $p(\gamma_k = 1) = \varepsilon$; μ_k, ζ_k are sequences of independent Gaussian variables with zero means and variances $\sigma_\mu^2, \sigma_\zeta^2$, respectively; besides, $\sigma_\mu < \sigma_\zeta$; $0 \leq \varepsilon \leq 1$ is the unknown fraction of contamination.

Given the model (14) and measured data $Z^N = \{r(1), \dots, r(N), y(1), \dots, y(N)\}$ and assuming that $\{\xi(k)\}$ is a process of the form (17)–(19), we determine the prediction

error estimate of the parameter vector $\omega^T = (c_1, c_2, \dots, c_m, d_1, d_2, \dots, d_m)$ by minimizing

$$\begin{aligned}\tilde{\omega}_N &= \arg \min_{\omega \in D_M} \tilde{V}_N(\theta, \omega, \varphi, \eta, Z^N), \\ \tilde{V}_N(\theta, \omega, \varphi, \eta, Z^N) &= \sum_{k=1}^N \rho(e_p(k/\theta, \omega, \varphi, \eta)/\sigma),\end{aligned}\quad (31)$$

or by solving the equation

$$\sum_{t=1}^N z(t) \{ \psi [y(t) - z^T(t)\omega] \} = 0 \quad (32)$$

in the vector form. Here $\tilde{\omega}_N$ is the estimate of the parameter vector ω , determined by processing N pairs of the reference signal and output samples, σ is the scale of residual (examples of the scale are the standard deviation, the median absolute deviation from the median, etc.), $\rho(\cdot)$ is a real-valued function that is even and nondecreasing for positive residuals, and $\rho(0) = 0$, $\psi = \rho'$.

For the Huber M -estimator, the ρ -function is given by

$$\rho(e) = \begin{cases} \lambda^2/2, & |e| \leq \kappa, \\ b|\lambda| - b^2/2, & |e| > \kappa, \end{cases} \quad (33)$$

where $e \equiv e_p(k/\theta, \omega, \varphi, \eta)$, κ is the cutoff value.

It is known (Huber, 1981) that the ρ -function is not strictly convex. Therefore, by minimizing this objective function, multiple solutions can be obtained which are close to one another. The score function

$$\psi(e_p(k/\theta, \omega, \varphi, \eta, Z^N)) = \partial \rho(e_p(k/\theta, \omega, \varphi, \eta, Z^N)) / \partial r \quad (34)$$

is an odd one. The various ψ functions give us various M estimates. Therefore, there always arises a question how to choose the proper ψ -function. The mostly used function ψ is (Huber, 1964):

$$\psi(x) = \begin{cases} x & \text{if } |x| \leq c_H, \\ c_H \text{sign } x & \text{if } |x| > c_H, \end{cases} \quad (35)$$

with given $c_H > 0$. To get a better performance of $\tilde{\omega}_N$ in a case of very long-tailed distributions, a function (35) satisfying

$$\psi(x) = 0 \quad \text{if } |x| > c_H \quad (36)$$

for some $c_H > 0$ could be selected. M -estimates are generally not scale equivariant. It means that instead of solving (32) we solve

$$\sum_{t=1}^N z(t) \psi \left\{ \frac{y(t) - z^T(t)\omega}{s} \right\} = 0, \quad (37)$$

where s is the robust estimate of the residuals scale, which according to Huber (1972) could be determined simultaneously with $\tilde{\omega}_N$.

5. Recursive Calculation of M -estimates

It is known (Novovičova, 1987) that in both such cases, i.e., $\varepsilon \neq 0$ and

$$H_0(q, a) = \frac{1}{A(q, a)} = \frac{1}{1 + a_1 q^{-1} + \dots + a_m q^{-m}}, \quad (38)$$

current M -estimates of unknown parameters of linear dynamic systems can be calculated using even three techniques:

1) the S -algorithm

$$\begin{aligned} \omega(k) &= \omega(k-1) \\ &+ \frac{P(k-1)z(k-1)}{\{\psi'([y(k) - z^T(k)\omega(k-1)]/s)\}^{-1} + z^T(k)P(k-1)z(k)} \\ &\times s\psi\{[y(k) - z^T(k)\omega(k-1)]/s\}, \end{aligned} \quad (39)$$

$$\begin{aligned} P(k) &= P(k-1) \\ &- \frac{P(k-1)z(k)z^T(k)P(k-1)}{\{\psi'([y(k) - z^T(k)\omega(k-1)]/s)\}^{-1} + z^T(k)P(k-1)z(k)}, \end{aligned} \quad (40)$$

2) the H -algorithm

$$\begin{aligned} \omega(k) &= \omega(k-1) \\ &+ \frac{P(k-1)z(k-1)}{1 + z^T(k)P(k-1)z(k)} s\psi\{[y(k) - z^T(k)\omega(k-1)]/s\}, \end{aligned} \quad (41)$$

$$P(k) = P(k-1) - \frac{P(k-1)z(k)z^T(k)P(k-1)}{1 + z^T(k)P(k-1)z(k)}, \quad (42)$$

3) and the W -algorithm

$$\begin{aligned} \omega(k) &= \omega(k-1) \\ &+ \frac{P(k-1)z(k-1)}{[w(k)]^{-1} + z^T(k)P(k-1)z(k)} s\psi\{[y(k) - z^T(k)\omega(k-1)]/s\} \end{aligned} \quad (43)$$

$$P(k) = P(k-1) - \frac{P(k-1)z(k)z^T(k)P(k-1)}{[w(k)]^{-1} + z^T(k)P(k-1)z(k)}, \quad (44)$$

$$w(k) = \begin{cases} s\psi \{ \mu(k)/s \} \mu(k) & \text{for } \mu(k) \neq 0, \\ \rho_0'' & \text{for } \mu(k) = 0, \end{cases} \quad (45)$$

$$\mu(k) = y(k) - z^T(k)\omega(k-1). \quad (46)$$

The *S*-algorithm represents a version of the algorithm proposed by Polyak and Cypkin (1980) for an on-line robust identification of parameters of the linear dynamic model. The robusting of the ordinary RLS (22)–(24) follows by substituting the “winsorization” step of the residuals in equation (22) and by modifying equation (23). The recursive *H*-algorithm is obtained only by inserting the “winsorization” step into equation (22). By comparing (43)–(44) to (22), (23) one can see, that the *W*-algorithm is obtained by inserting different weights in respect to the function $\psi \{ \cdot \}$ into the already existing ordinary RLS.

The various robust recursive techniques used for the parameter estimation of open-loop dynamic systems when the additive noise filter $H(q, \varphi)$ is of different form than that of (38), are proposed in (Pupeikis, 1994).

6. Numerical Simulation

The closed-loop system to be simulated is shown in Fig. 3 and is described by the linear difference equation of the form (Åström, 1987)

$$(1 + aq^{-1})y(k) = (1 + bq^{-1})u(k) + (1 + cq^{-1})\xi(k), \quad k = 1, 2, \dots, 100, \quad (47)$$

where $a = -0.985$; $b = 0.75$; $c = -0.7$.

The feedback is simplified to

$$u(k) = g(k)e(k), \quad (48)$$

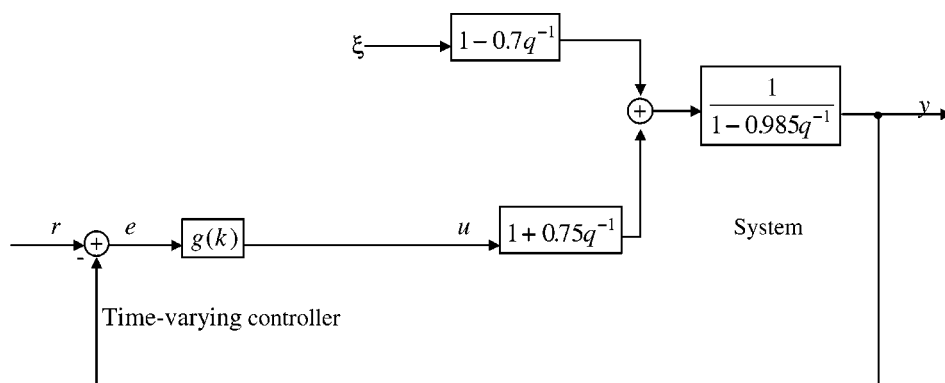

Fig. 3. Simulated closed-loop system with an additive correlated noise and the reference signal r .

with

$$e(k) = r(k) - y(k). \quad (49)$$

Here $g(k) = 0.25$ for $k < 40$ and $g(k) = 0.75$ for $k \geq 40$, the output $y(k)$, $k = 0, 1, 2, \dots, 100$ of the closed-loop system is observed under the additive noise $\xi(k)$, $k = 0, 1, 2, \dots, 100$ containing outliers. The reference signal $r(k)$ and the noise $\xi(k)$ are generated by means of the Matlab functions *randn* and *rand*, respectively (Pupeikis, 2000).

From (47) it follows that $G_0(q, \theta)$ has the form

$$G_0(q, \theta) = \frac{1 + bq^{-1}}{1 + aq^{-1}}. \quad (50)$$

Then substituting (50) and $G_R(q, \alpha) = g(k)$ into the equality (10) we obtain the output sensitivity function of the form

$$\Phi_0(q, \beta) = \frac{1 + aq^{-1}}{1 + g(k) + [a + g(k)b]q^{-1}}. \quad (51)$$

Moreover, we can rewrite the relation (13) of the closed-loop system (Fig. 3) as

$$y(k) = \Phi_0(q, \beta)r^*(k) + \xi^*(k), \quad (52)$$

where

$$\begin{aligned} r^*(k) &= G_0(q, \theta)G_R(q, \alpha)r(k), \\ \xi^*(k) &= H_0^c(q, \varphi)\xi(k). \end{aligned} \quad (53)$$

For the LTI system (36) the relation (53) has the form

$$y(k) = \beta_0 r^*(k) + \beta_1 r^*(k-1) + \beta_2 y(k-1) + \xi^*(k), \quad (54)$$

where

$$\begin{aligned} \beta_0 &= [1 + g(k)]^{-1}, \\ \beta_1 &= a\beta_0, \\ \beta_2 &= -[a + g(k)b]\beta_0, \end{aligned} \quad (55)$$

$$r^*(k) = g(k) [1 + bq^{-1}] [1 + aq^{-1}]^{-1} r(k), \quad (56)$$

here the parameter β_0 is known beforehand.

We simplify the problem determining the estimates of parameters β_1, β_2 of the equation (54). The technique for the determination of current estimates consist of such steps:

1. New observations $y(k)$ and $r(k)$ are made at time k .

2. Filtered current observation of the reference signal is determined

$$r^*(k) = g(k) \frac{1 + b(k-1)q^{-1}}{1 + a(k-1)q^{-1}} r(k). \quad (57)$$

3. The estimates of parameters β_1, β_2 by processing the pair of observations $y(k)$ and $r(k)$ using the ordinary RLS (22), (24) and the H -technique (41)–(42) are obtained.
4. Assuming that $g(k)$ is known and the relations

$$a = \beta_1 (1 + g(k)), \quad b = -\frac{\beta_2 + \beta_0 a}{g(k)\beta_0} \quad (58)$$

are valid the current estimates of $a = -0.985$; $b = 0.75$ substituting in (58) the estimates of β_1, β_2 are determined.

5. Replace $(k+1)$ by k and start again with Step 1.

In Figs. 4–6 simulated input $u(k)$ (a), noisy output $y(k)$ and reference signal $r(k)$ for $k = 1, 2, \dots, 100$ (b) of the closed-loop system (Fig. 3), are shown. The parts (c), (d) of above mentioned figures correspond to the estimates of $a = -0.985$, $b = 0.75$ obtained by means of the ordinary RLS. Fig. 4 corresponds to the case when there are no outliers in the correlated noise $v(k)$, $k = 0, 1, 2, \dots$, at all. On the other hand, the curves in Fig. 5c, d and 6c, d are determined when respective inputs (5a, 6a) and outputs (5b, 6b) in the presence of outliers in observations used for the current estimation of β_1, β_2 are measured. It follows that the accuracy of estimates is lower, when there appears an additive noise even with one isolated outlier (Fig. 5c, d) as compared to the case where there is no outlier in observations (Fig. 4c, d). The estimation results for the case of five outliers (Fig. 6c, d) in observations to be processed are also shown in Fig. 7. Here we use the ordinary RLS (7a) and the H -technique (7b). It should be noted that the accuracy of estimates (solid and dashed lines) obtained by the H -technique (Fig. 7b) is higher than that of estimates calculated by the ordinary RLS (Fig. 7a). Such an accuracy can be increased if the procedure decorrelating the additive noise could be used.

7. Conclusions

Outliers in observations to be processed strongly influence the quality of the performance of a closed-loop system. For the estimation of parameters of such a system, the indirect approach that identifies the sensitivity function of the closed-loop system using observations of the reference signal and noisy output, and the robust H -technique calculating M -estimates applying Huber's $\psi\{\cdot\}$ function could be used. Moreover, it is assumed that the parameters of the controller are known, because only in such a case we have the possibility to determine the parameters of the transfer function of an open-loop system. In such a case the accuracy of estimates is increased in comparison with the estimates obtained by the ordinary RLS (Fig. 7).

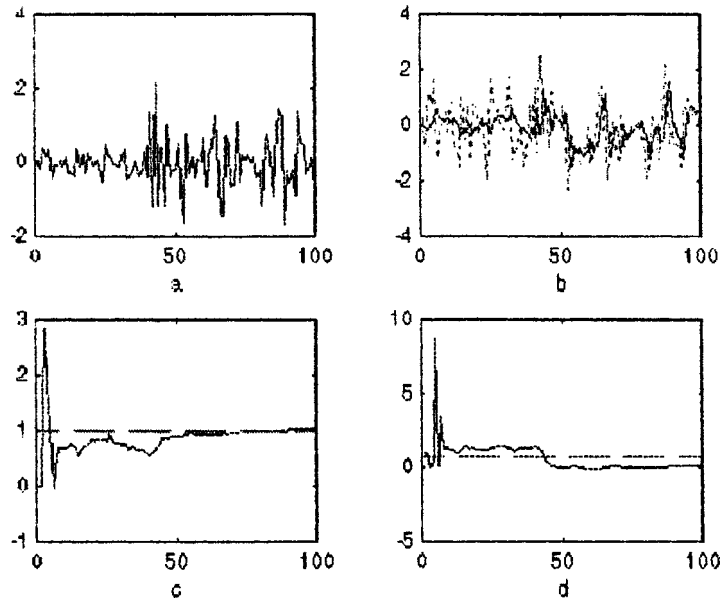

Fig. 4. Signals of the closed-loop system (47) (a, b) and the estimates of parameters (c, d), obtained by the ordinary RLS, in the presence of an additive correlated noise on the output: x -axis – numbers of observations, y -axis – amplitudes (a, b), values of the parameters (c, d), input u – (a), output y , and the reference signal r (dotted line) – (b), the current estimate of parameters a, b – (c, d), respectively. Dotted lines in c, d correspond to the true values of a, b .

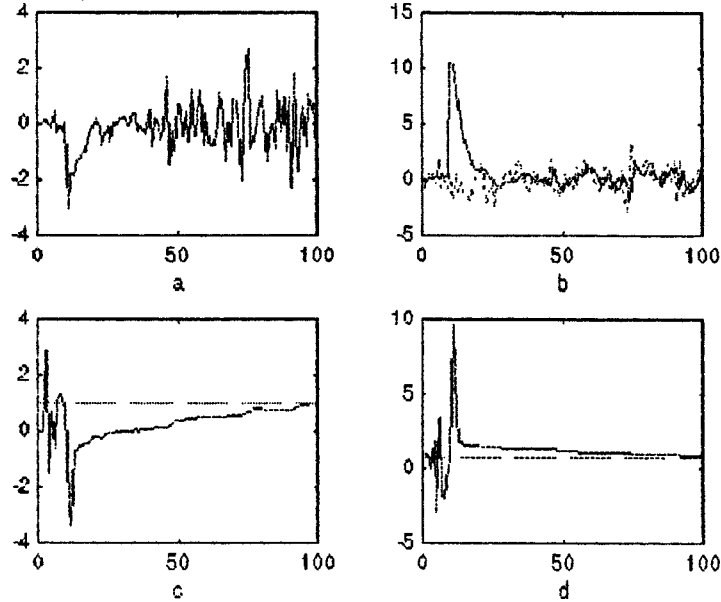

Fig. 5. Signals of the closed-loop system (47) (a, b) and the estimates of parameters (c, d) obtained using the ordinary RLS in the presence of an additive correlated noise on the output with the one outlier in it. Other values and markings are the same as in Fig. 4.

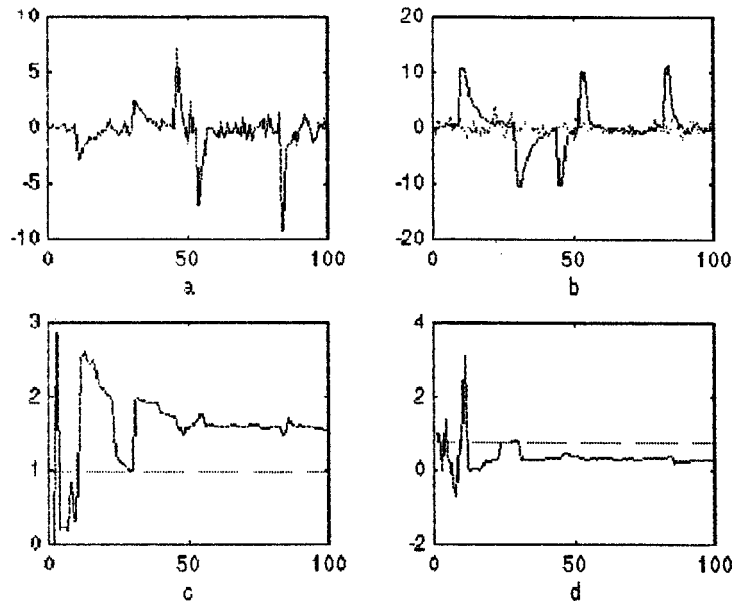

Fig. 6. Signals of the closed-loop system (47) (a, b) and the estimates of parameters (c, d) in the presence of an additive correlated noise on the output with five outliers in it. Other values and markings are the same as in Fig. 4.

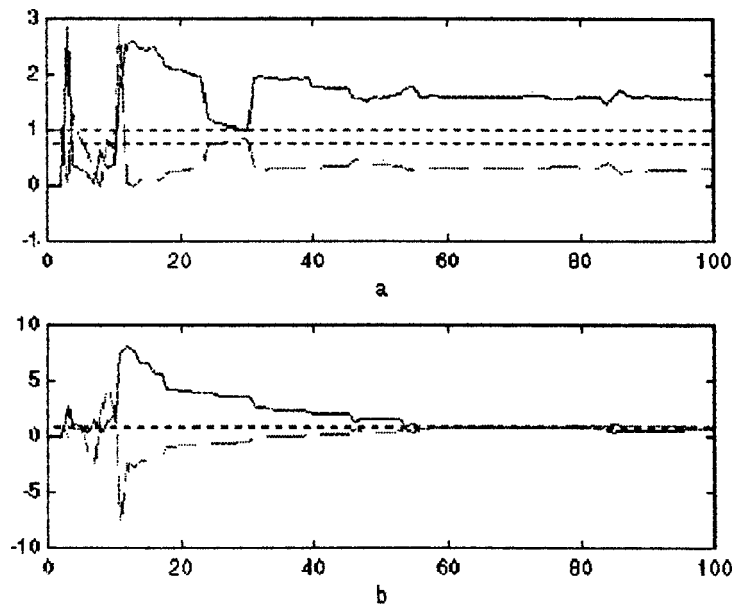

Fig. 7. Dependence of current estimates (solid and dashed lines) of the parameters a , b on the number of recursive iterations. Estimates are calculated using observations of the reference signal and the noisy output with five outliers in an additive correlated noise. Recursive technique: a – the ordinary RLS, b – the robust M -algorithm with Huber's ψ -function (35).

References

- Åström, K.J. (1987). Adaptive feedback control. *Proc. of the IEEE*, **75**(2), 185–217.
- Forsell, U., and L. Ljung (1999). Closed-loop identification revisited. *Automatica*, **35**, 1215–1241.
- Forsell, U., and L. Ljung (2000). Some results on optimal experiment design. *Automatica*, **36**, 749–756.
- Gustavsson, I., L.L. Ljung and T. Söderström (1977). Identification of processes in closed loop – identifiability and accuracy aspects. *Automatica*, **13**, 59–75.
- Isermann, R. (1982). Parameter adaptive control algorithms – a tutorial. *Automatica*, **18**(5), 513–528.
- Huber, P. J. (1964). Robust estimation of a location parameter. *Ann. Math. Statist.*, **35**, 73–101.
- Huber, P. J. (1972). Robust statistics. A review. *Ann. Math. Statist.*, **1**, 799–821.
- Huber, P. J. (1981). *Robust Statistics*. J. Wiley. New York.
- Ljung, L. (1978). Convergence analysis of parametric identification methods. *IEEE Trans. on Automat. Control*, **23**, 770–783.
- Novovičova, J. (1987). Recursive computation of M -estimates for the parameters of the linear dynamical systems. *Problems of Control and Information Theory*, **16**(1), 4–59.
- Polyak, B. T., and Ya. Z. Tsytkin (1980). Robust identification. *Automatica*, **16**(1), 53–65.
- Pupeikis, R. (1994). On-line estimation of dynamic systems parameters in the presence of outliers in observations. *Informatica*, **5**(1–2), 189–210.
- Pupeikis, R. (2000). Closed-loop robust identification using the direct approach. *Informatica*, **11**(2), 163–178.
- Pupeikis, R. (2000). *Signalų kūrimas Matematiko terpeje*. Vilnius, Technika (in Lithuanian).
- Söderström, T., P. Stoica and B. Friedlander (1991). An indirect prediction error method for system identification. *Automatica*, **27**(1), 183–188.

R. Pupeikis received Ph.D. degree from the Kaunas Polytechnic Institute, Kaunas, Lithuania, 1979. He is a senior researcher at the Process Recognition Department of the Institute of Mathematics and Informatics and the Associated Professor at the Gediminas technical university. His research interest include the classical and robust approaches of dynamic system identification as well technological process control.

Uždaro ciklo sistemų patvarusis identifikavimas, taikant netiesioginį metodą

Rimantas PUPEIKIS

Straipsnyje adityviojo triukšmo su dideliais retais nuokrypiais atveju plėtojamas netiesioginis metodas, kuris taikomas uždaro ciklo diskretinio laiko dinaminių sistemų identifikavimui. Nežinomų parametrų M -įverčiams gauti, apdorojant bazinio signalo ir užtriukšminto išėjimo stebėjimus pasiūlytas ir modeliuojant kompiuteriu ištirtas patvarusis H-algoritmas. Gauti dinaminės sistemos parametrų skaičiavimų rezultatai, taikant du rekurentinius algoritmus: mažiausiųjų kvadratų ir H-algoritmą su netiesine Huberio funkcija.