

# Closed-loop Robust Identification Using the Direct Approach

Rimantas PUPEIKIS

*Institute of Mathematics and Informatics, Vilnius Gediminas Technical University  
Akademijos 4, 2000 Vilnius, Lithuania  
e-mail: pupeikis@ktl.mii.lt*

Received: March 2000

**Abstract.** The aim of the given paper is a development of the direct approach used for the estimation of parameters of a closed-loop discrete-time dynamic system in the case of additive noise with outliers contaminated uniformly in it (Fig. 1). To calculate  $M$ -estimates of unknown parameters of such a system by means of processing input and noisy output observations (Fig. 2), the recursive robust  $H$ -technique based on an ordinary recursive least square (RLS) algorithm is applied here. The results of numerical simulation of closed-loop system (Fig. 3) by computer (Figs. 4–7) are given.

**Key words:** adaptive system, closed-loop, direct approach, identification, observations, outliers.

## 1. Introduction

Adaptive control systems act while the properties of controlled processes and signals are varying in time. The quality of performance of an adaptive control system strongly depends on the accuracy of a tuned process model and on the closed-loop identification method to be applied. One can divide these identification methods into three groups (Isermann, 1982): a direct approach, an indirect approach and an joint input-output approach. The direct approach ignores the feedback and identifies the open-loop system using only input-output observations. It is known (Forsell and Ljung, 1999) that the direct approach gives consistency and optimal accuracy in spite of the feedback when the noise and the model of the dynamic system contain a true description. On the other hand, if the output is corrupted by an additive noise containing outliers, then the ordinary prediction error methods used to identify even unknown parameters of an open-loop dynamic system, described by the difference equation, could be of little use. Therefore, in such a case there arise a problem of the closed-loop robust identification by processing input and noisy output observations. It can be solved applying Huber's robust location parameter estimation ideas (Huber, 1964) and respective robust techniques based on the ordinary Kalman filter (Pupeikis and Huber, 1997; Pupeikis, 1998, 1999) used for the state estimation, which can be easily suited to the parameter estimation of dynamic systems in the case of outliers in observations to be processed (Novovičova, 1987).

## 2. The Statement of the Problem

Assume that the control system to be observed is causal, linear and time-invariant (LTI) with one output  $\{y(k)\}$ ,  $k = 1, 2, \dots$  and one input  $\{u(k)\}$ ,  $k = 1, 2, \dots$  and given by the equation

$$\begin{aligned} y(k) &= G_0(q, \theta)u(k) + v(k), \\ v(k) &= H_0(q)\xi(k), \end{aligned} \quad (1)$$

which consists of two parts: a process model  $G_0(q, \theta)$  and a noise one  $H_0(q)$ .

Here  $\theta$  is the unknown parameter vector to be estimated,  $q$  is the time-shift operator (i.e.,  $q^{-1}u(k) = u(k-1)$ ), the initial signal  $\{\xi(k)\} = 1, 2, \dots$  used to generate unmeasurable noise is assumed to be statistically independent and stationary with

$$\begin{aligned} E\{\xi(k)\} &= 0, \\ E\{\xi(k)\xi(k+\tau)\} &= \sigma_\xi^2 \delta(\tau). \end{aligned} \quad (2)$$

$E\{\cdot\}$  is a mean value,  $\sigma_\xi^2$  is a variance,  $\delta(\tau)$  is the Kronecker delta function,  $H_0(q)$  is an inversely stable, monic filter.

The input  $\{u(k)\}$ ,  $k = 1, 2, \dots, N$  is given by

$$u(k) = \Psi(k, y^k, u^{k-1}, r(k)), \quad (3)$$

where  $y^k = [y(1), \dots, y(k)]$ ,  $u^{k-1} = [u(1), \dots, u(k-1)]$ . The reference signal  $\{r(k)\}$ ,  $k = 1, 2, \dots$  is a quasi-stationary signal, independent of the stochastic disturbance  $\{v(k)\}$ ,  $k = 1, 2, \dots$  and  $\Psi$  is a given deterministic function such that the closed-loop system (1), (2) with the controller  $G_R(q)$  (see Fig. 1), which is designed for disturbance  $\{v(k)\}$ ,  $k = 1, 2, \dots$  by minimizing a quadratic performance function

$$J = \lim_{N \rightarrow \infty} E \left\{ \frac{1}{N} \sum_{k=0}^{N-1} y^2(k) + \rho u^2(k) \right\}, \quad (4)$$

is exponentially stable (Forsell and Ljung, 1999). Here the factor  $0 < \rho \leq 1$ .

The basis of identification is the data set  $Z^N = \{u(1), \dots, u(N), y(1), \dots, y(N)\}$  consisting of measured observations of the input  $\{u(k)\}$  and output  $\{y(k)\}$ ,  $k = 1, 2, \dots, N$  signals.

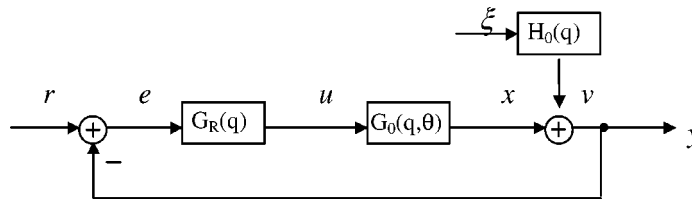

Fig. 1. A closed-loop system to be observed.

The aim of the given paper is to estimate the parameter vector  $\theta$  of the closed-loop LTI system (1), (2) shown in Fig. 1, using the above mentioned data set when assumption (2) is not satisfied because of occasionally appearing outliers in an unmeasurable noise signal  $\{v(k)\}$ ,  $k = 1, 2, \dots$

### 3. The Direct Approach for the Closed Loop System

First assume that assumption (2) referring to the unmeasurable noise signal  $\{v(k)\}$ ,  $k = 1, 2, \dots$  is valid. We choose a model structure of the form

$$y(k) = G(q, \theta)u(k) + H(q, \theta)\xi(k) \quad (5)$$

where  $G(q, \theta)$  corresponds to the first part of equation (1) and  $H(q, \theta)$  – to the second one. The prediction error is

$$e(k, \theta) = y(k) - \hat{y}(k, \theta) = H^{-1}(q, \theta)(y(k) - G(q, \theta)u(k)), \quad (6)$$

where the one-step-ahead predictor for the model structure (5) according to Ljung (1987) is

$$\hat{y}(k, \theta) = H^{-1}(q, \theta)G(q, \theta)u(k) + (1 - H^{-1}(q, \theta))y(k). \quad (7)$$

Given the model (5) and measured data  $Z^N$  we determine the prediction error estimate using formulas (Forsell and Ljung, 1999):

$$\begin{aligned} \hat{\theta}_N &= \arg \min_{\theta \in D_M} V_N(\theta, Z^N), \\ V_N(\theta, Z^N) &= \frac{1}{N} \sum_{t=1}^N e_F^T(k, \theta) \Lambda^{-1} e_F(k, \theta), \\ e_F(k, \theta) &= L(q, \theta)e(k, \theta), \end{aligned} \quad (8)$$

Here  $\Lambda$  is a symmetric, positive definite weighting matrix and  $L$  is a monic prefilter that can be used to enhance certain frequency regions.

It is known (Forsell and Ljung, 1999) that

$$e_F(k, \theta) = L(q, \theta)H^{-1}(q, \theta)(y(k) - G(q, \theta)u(k)). \quad (9)$$

The direct approach allows us to apply the well known prediction error techniques directly to input-output observations, ignoring a possible feedback and using the block scheme shown in Fig. 2. Thus, the parameter vector  $\theta$  can be determined by the ordinary least squares method (LS) by minimizing the sum of the form

$$\sum_{t=1}^N [y(t) - z^T(t)\theta]^2 = \min!, \quad (10)$$

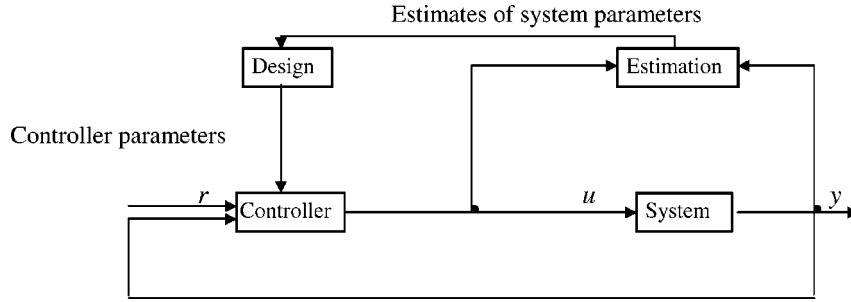

Fig. 2. Parameter adaptive self-organizing system.

where  $z^T(\cdot)$  is a vector of observations of the input  $\{u(k)\}$  and noisy output  $\{y(k)\}$ ,  $k = 1, 2, \dots, N$  signals.

It is known that the direct approach is the same as the ordinary open-loop prediction error method based on the RLS

$$\theta(k) = \theta(k-1) + \frac{P(k-1)z(k-1)}{1 + z^T(k)P(k-1)z(k)} [y(k) - z^T(k)\theta(k-1)], \quad (11)$$

$$P(k) = P(k-1) - \frac{P(k-1)z(k)z^T(k)P(k-1)}{1 + z^T(k)P(k-1)z(k)}, \quad (12)$$

with the vector of observations

$$z^T(k) = (u(k-1), \dots, u(k-m), y(k-1), \dots, y(k-m)) \quad (13)$$

and some initial values of the vector  $\theta(0)$  and of the matrix  $P(0)$ , when  $G_0(q, \theta)$  is the system transfer function of the form

$$G_0(q, \theta) = \frac{B(q, b)}{A(q, a)} = \frac{b_1q^{-1} + b_2q^{-2} + \dots + b_mq^{-m}}{1 + a_1q^{-1} + \dots + a_mq^{-m}}. \quad (14)$$

Here

$$\theta^T(k) = (b_1(k), b_2(k), \dots, b_m(k), a_1(k), a_2(k), \dots, a_m(k)) \quad (15)$$

is an estimate of the parameter vector

$$\theta^T = (b_1, b_2, \dots, b_m, a_1, a_2, \dots, a_m). \quad (16)$$

It can be mentioned that, in such a case, the respective identifiability conditions should be satisfied according to Isermann (1982).

#### 4. The Direct Approach in a Presence of Outliers in Observations

Assume now that the white noise  $\{\xi(k)\}$ ,  $k = 1, 2, \dots$  really is a sequence of independent identically distributed variables with an  $\varepsilon$ -contaminated distribution of the form

$$p(\xi(k)) = (1 - \varepsilon)N(0, \sigma_\mu^2) + \varepsilon N(0, \sigma_\zeta^2), \quad (17)$$

and the variance

$$\sigma_\xi^2 = (1 - \varepsilon)\sigma_\mu^2 + \varepsilon\sigma_\zeta^2; \quad (18)$$

$p(\xi(k))$  is the probability density distribution of the sequence  $\{\xi(k)\}$ ,  $k = 1, 2, \dots$ :

$$\xi(k) = (1 - \gamma_k)\mu_k + \gamma_k\zeta_k \quad (19)$$

is the value of the sequence  $\{\xi(k)\}$ ,  $k = 1, 2, \dots$  at a time moment  $k$ ;  $\gamma$  is a random variable, taking values 0 or 1 with probabilities  $p(\gamma_k = 0) = 1 - \varepsilon$ ,  $p(\gamma_k = 1) = \varepsilon$ ;  $\mu_k, \zeta_k$  are sequences of independent Gaussian variables with zero means and variances  $\sigma_\mu^2, \sigma_\zeta^2$ , respectively; besides,  $\sigma_\mu < \sigma_\zeta$ ;  $0 \leq \varepsilon \leq 1$  is the unknown fraction of contamination.

Given the model (5) and measured data  $Z^N = \{u(1), \dots, u(N), y(1), \dots, y(N)\}$  and assuming that  $\{\xi(k)\}$  is a process of the form (17)–(19), we determine the prediction error estimate of the parameter vector  $\theta^T = (b_1, b_2, \dots, b_m, a_1, a_2, \dots, a_m)$  by minimizing

$$\begin{aligned} \hat{\theta}_N &= \arg \min_{\theta \in D_M} \hat{V}_N(\theta, Z^N), \\ \hat{V}_N(\theta, Z^N) &= \sum_{k=1}^N \rho(e_F(k, \theta)/\sigma), \end{aligned} \quad (20)$$

or by solving the equation

$$\sum_{t=1}^N z(t) [\psi(y(t) - z^T(t)\theta)] = 0, \quad (21)$$

in the vector form.

Here  $\hat{\theta}_N$  is the robust estimate of the parameter vector  $\theta$ , determined by processing  $N$  pairs of input-output samples,  $\sigma$  is the scale of residual (examples of the scale are the standard deviation, the median absolute deviation from the median, etc.),  $\rho(\cdot)$  is a real-valued function that is even and nondecreasing for positive residuals, and  $\rho(0) = 0$ ,  $\psi = \rho'$ .

For the Huber  $M$ -estimator, the  $\rho$ -function is given by

$$\rho(r) = \begin{cases} r^2/2, & |r| \leq b \\ b|r| - b^2/2, & |r| > b \end{cases}, \quad (22)$$

where  $b$  is the cutoff value.

It is known (Huber, 1981) that the  $\rho$ -function is not strictly convex. Therefore, by minimizing this objective function, multiple solutions can be obtained which are close to one another. The score function

$$\psi(r(\theta, Z^N)) = \partial\rho(r(\theta, Z^N))/\partial r \quad (23)$$

is an odd one. The various  $\psi$  functions give us various  $M$  estimates. Therefore, there always arises a question how to choose the proper  $\psi$ -function. The mostly used function  $\psi$  is (Huber, 1964):

$$\psi(x) = \begin{cases} x & \text{if } |x| \leq c_H, \\ c_H \text{sign } x, & \text{if } |x| > c_H, \end{cases} \quad (24)$$

with given  $c_H > 0$ . To get a better performance of  $\hat{\theta}_N$  in a case of very long-tailed distributions, a function (20) satisfying

$$\psi(x) = 0, \quad \text{if } |x| > c, \quad (25)$$

for some  $c > 0$  could be selected.  $M$ -estimates are generally not scale equivariant. It means that instead of solving (21) we solve

$$\sum_{t=1}^n z_t \psi \left( \frac{y_t - z_t^T \theta}{s} \right) = 0, \quad (26)$$

where  $s$  is the robust estimate of the residuals scale, which according to Huber, 1972 could be determined simultaneously with  $\theta$ .

## 5. Recursive Calculation of $M$ -estimates

It is known (Novovičova, 1987) that in both such cases, i.e.,  $\varepsilon \neq 0$  and

$$H_0(q, a) = \frac{1}{A(q, a)} = \frac{1}{1 + a_1 q^{-1} + \dots + a_m q^{-m}}, \quad (27)$$

current  $M$ -estimates of unknown parameters of linear dynamic systems can be calculated using even three techniques:

1) the  $S$ -algorithm

$$\begin{aligned} \theta(k) = & \theta(k-1) \\ & + \frac{P(k-1)z(k-1)}{\left\{ \psi' \left( [y(k) - z^T(k)\theta(k-1)]/s \right) \right\}^{-1} + z^T(k)P(k-1)z(k)} \\ & \times s\psi \left\{ [y(k) - z^T(k)\theta(k-1)]/s \right\}, \end{aligned} \quad (28)$$

$$P(k) = P(k-1) - \frac{P(k-1)z(k)z^T(k)P(k-1)}{\left\{ \psi' \left( [y(k) - z^T(k)\theta(k-1)]/s \right) \right\}^{-1} + z^T(k)P(k-1)z(k)}, \quad (29)$$

2) the  $H$ -algorithm

$$\theta(k) = \theta(k-1) + \frac{P(k-1)z(k-1)}{1 + z^T(k)P(k-1)z(k)} s\psi \{ [y(k) - z^T(k)\theta(k-1)]/s \}, \quad (30)$$

$$P(k) = P(k-1) - \frac{P(k-1)z(k)z^T(k)P(k-1)}{1 + z^T(k)P(k-1)z(k)}, \quad (31)$$

3) the  $W$ -algorithm

$$\theta(k) = \theta(k-1) + \frac{P(k-1)z(k-1)}{[w(k)]^{-1} + z^T(k)P(k-1)z(k)} \times s\psi \{ [y(k) - z^T(k)\theta(k-1)]/s \}, \quad (32)$$

$$P(k) = P(k-1) - \frac{P(k-1)z(k)z^T(k)P(k-1)}{[w(k)]^{-1} + z^T(k)P(k-1)z(k)}, \quad (33)$$

$$w(k) = \begin{cases} s\psi \{ \alpha(k)/s \} \alpha(k) & \text{for } \alpha(k) \neq 0 \\ \rho_0'' & \text{for } \alpha(k) = 0 \end{cases}, \quad (34)$$

$$\alpha(k) = y(k) - z^T(k)\theta(k-1). \quad (35)$$

The  $S$ -algorithm represents a version of the algorithm proposed by Polyak and Cypkin (1980) for an on-line robust identification of parameters of the linear dynamic model. The robusting of the ordinary RLS (11), (12) (13) follows by substituting the “winsorization” step of the residuals in equation (11) and by modifying equation (12). The recursive  $H$ -algorithm is obtained only by inserting the “winsorization” step into equation (11). By comparing (32)–(35) to (11),(12) one can see, that the  $W$ -algorithm is obtained by inserting different weights in respect to the function  $\psi\{\cdot\}$  into the already existing ordinary RLS.

The various robust recursive techniques used for the parameter estimation of open-loop dynamic systems when the noise filter  $H(q, \theta)$  is of different form than that of (27), are proposed in (Pupeikis, 1994).

## 6. The Covariance Matrix for the Robust Estimates

The covariance matrix is

$$\text{cov}\{\theta_{LS}(N)\} = [1/(N-2m)] \left( \sum_{i=p}^N r_i^2 \right) (X^T X)^{-1}, \quad (36)$$

when the estimate  $\theta_{LS}(N)$  of the form (15) by the ordinary RLS (11)–(13) is determined.

Here  $N$  is the whole number of the pairs of observations of the input  $\{u(k)\}$  and noisy output  $\{y(k)\}$ ,  $p > m$ ,

$$r_i = y(i) - z^T(i)\theta(N), \quad (37)$$

$$z^T(i) = (u(i-1), \dots, u(i-m), -y(i-1), \dots, -y(i-m)), \quad (38)$$

$$\theta_{LS}^T(N) = (b_1(N), b_2(N), \dots, b_m(N), a_1(N), a_2(N), \dots, a_m(N)), \quad (39)$$

$$X = \begin{bmatrix} u(p-1)u(p-2)\dots u(p-m) - y(p-1) - y(p-2)\dots - y(p-m) \\ u(p)u(p-1)\dots u(p-m+1) - y(p) - y(p-1)\dots - y(p-m+1) \\ \dots \\ u(N-1)u(N-2)\dots u(N-m) - y(N-1) - y(N-2)\dots - y(N-m) \end{bmatrix}. \quad (40)$$

The expression (36) in a case of robust estimates according to Huber, (1981) can be rewritten as

$$\text{cov}\{\hat{\theta}_N\} = \left\{ E[\psi^2(x)] / (E[\psi'(x)])^2 \right\} (X^T X)^{-1}, \quad (41)$$

or in such a form

$$\text{cov}\{\hat{\theta}_N\} \approx \frac{(1/N) \sum_{i=p}^N \psi^2(r_i)}{\left[ (1/N) \sum_{i=p}^N \psi'(r_i) \right]^2} (X^T X)^{-1}, \quad (42)$$

for a limited  $N$ .

It is known (Huber, 1981) that there exist even three formulas for the unbiased estimates of  $\text{cov}\{\hat{\theta}_N\}$ :

$$K^2 \frac{[1/(N-p)] \sum_{i=p}^N \psi^2(r_i)}{\left[ (1/N) \sum_{i=p}^N \psi'(r_i) \right]^2} (X^T X)^{-1}, \quad (43)$$



$$K \frac{[1/(N-p)] \sum_{i=p}^N \psi^2(r_i)}{(1/N) \sum_{i=p}^N \psi'(r_i)} W^{-1}, \quad (44)$$

$$K^{-1} \frac{1}{N-p} \sum_{i=p}^N \psi^2(r_i) W^{-1} (X^T X) W^{-1}, \quad (45)$$

where  $W$  is the matrix of weights,

$$K = 1 + \frac{p}{N} \frac{D(\psi')}{[E(\psi')]^2}, \quad (46)$$

$$E(\psi') \approx \phi = (1/N) \sum_{i=p}^N \psi'(r_i), \quad (47)$$

$$D(\psi') \approx (1/N) \sum_{i=p}^N (\psi'(r_i) - \phi)^2. \quad (48)$$

The expression (46) can be simplified, if  $\psi(x) = \min [c, \max(-c, x)]$ . Thus,

$$K = 1 + \frac{p}{N} \frac{1 - \phi}{\phi}, \quad (49)$$

where  $\phi$  is the relative frequency of the residuals  $r_i$ ,  $-c < r_i < c$ .

## 7. Numerical Simulation

The closed-loop system to be simulated is shown in Fig. 3 and is described by the linear difference equation of the form (Åström, 1987; Halwass, 1988)

$$(1 + aq^{-1})y(k) = (1 + bq^{-1})u(k) + (1 + cq^{-1})\xi(k). \quad (50)$$

The controller design equation is

$$u(k) = e(k) + 0.1005u(k-1) - 0.1016u(k-2), \quad (51)$$

where

$$e(k) = r(k) - y(k). \quad (52)$$

The output  $y(k)$ ,  $k = 0, 1, 2, \dots$  of the closed-loop system is observed under the additive noise  $v(k)$ ,  $k = 0, 1, 2, \dots$  containing outliers according to (17)–(19).

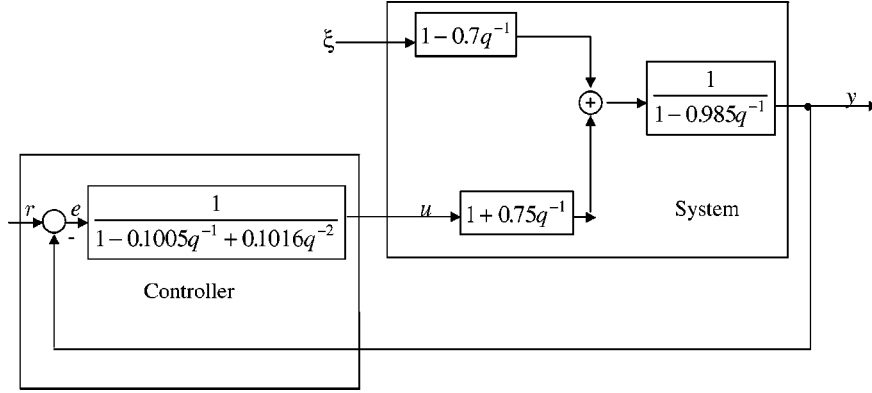

Fig. 3. Simulated closed-loop system with an additive correlated noise and the reference signal  $r$  where  $a = -0.985$ ;  $b = .75$ ;  $c = -0.7$ .

Now we rewrite the recursive  $H$ -algorithm (30), (31) for the first-order system

$$y(k) + a_1 y(k-1) = b_1 u(k-1) + \xi(k), \quad (53)$$

or the same in the different form

$$y(k) = \varphi^T(k) \theta(k) + \xi(k), \quad (54)$$

if instead of unknown parameters  $a_1, b_1$  their respective estimates  $a_1(k), b_1(k)$  are substituted in equation (53).

Here

$$\varphi^T(k) = [-y(k-1)u(k-1)], \quad (55)$$

$$\theta(k) = [a_1(k)b_1(k)]^T. \quad (56)$$

The algorithm for the determination of current estimates  $a_1(k), b_1(k)$  of unknown parameters  $a_1, b_1$  by processing the observations  $y(k)$  and  $u(k)$  will be alike to the one proposed in (Isermann, 1982):

1. New observations  $y(k)$  and  $u(k)$  are made at time  $k$ .

$$e(k) = y(k) - [-y(k-1)u(k-1)] \begin{bmatrix} a_1(k-1) \\ b_1(k-1) \end{bmatrix}. \quad (57)$$

3. New parameter estimates are calculated

$$\begin{bmatrix} a_1(k) \\ b_1(k) \end{bmatrix} = \begin{bmatrix} a_1(k-1) \\ b_1(k-1) \end{bmatrix} + \begin{bmatrix} \gamma_1(k-1) \\ \gamma_2(k-1) \end{bmatrix} \psi[e(k)], \quad (58)$$

where  $\gamma_1(k-1)$ ,  $\gamma_2(k-1)$  from Step 7, and  $\psi[e(k)]$  is of the form (24).

4. Observations  $y(k)$  and  $u(k)$  are inserted into

$$\varphi^T(k+1) = [-y(k)u(k)]. \quad (59)$$

5.

$$\begin{aligned} P(k)\varphi(k+1) &= \begin{bmatrix} p_{11}(k) & p_{12}(k) \\ p_{21}(k) & p_{22}(k) \end{bmatrix} \begin{bmatrix} -y(k) \\ u(k) \end{bmatrix} \\ &= \begin{bmatrix} -p_{11}(k)y(k) + p_{12}(k)u(k) \\ -p_{21}(k)y(k) + p_{22}(k)u(k) \end{bmatrix} = \begin{bmatrix} i_1 \\ i_2 \end{bmatrix}, \end{aligned} \quad (60)$$

where  $P(k)$  is from Step 8.

6.

$$\begin{aligned} \varphi^T(k+1)P(k)\varphi(k+1) &= p_{11}(k)y^2(k) - (p_{12}(k) \\ &\quad + p_{21}(k))u(k)y(k) + p_{22}(k) \cdot u^2(k) = j. \end{aligned} \quad (61)$$

7.

$$\begin{bmatrix} \gamma_1(k) \\ \gamma_2(k) \end{bmatrix} = \frac{1}{j + \lambda} \begin{bmatrix} i_1 \\ i_2 \end{bmatrix}. \quad (62)$$

8.

$$\begin{aligned} P(k+1) &= \frac{1}{\lambda} \begin{bmatrix} 1 + \gamma_1(k)y(k) - \gamma_1(k)u(k) \\ \gamma_2(k)y(k)1 - \gamma_2(k)u(k) \end{bmatrix} \\ &\quad \times \begin{bmatrix} p_{11}(k)p_{12}(k) \\ p_{21}(k)p_{22}(k) \end{bmatrix}. \end{aligned} \quad (63)$$

9. Replace  $(k+1)$  by  $k$  and start again with Step 1.

To start the recursive algorithms at time  $k=0$  one uses

$$\hat{\theta}(0) = \begin{bmatrix} 0 \\ 0 \end{bmatrix} \quad \text{and} \quad P(0) = \begin{bmatrix} \alpha & 0 \\ 0 & \alpha \end{bmatrix},$$

where  $\alpha$  is a large number,  $0.95 \leq \lambda \leq 0.995$ .

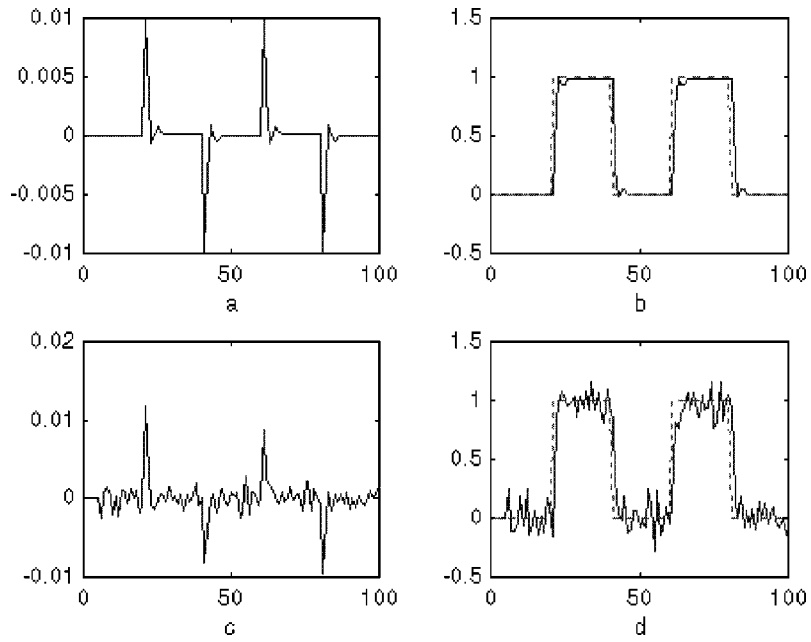

Fig. 4. Signals of the closed-loop system (50) in the absence (*a, b*) and in the presence (*c, d*) of an additive correlated noise on the output: *x*-axis – numbers of observations, *y*-axis – amplitudes, inputs  $u$  – *a, c*, outputs  $y$ , and the reference signal  $r$  (dotted line) – (*b, d*).

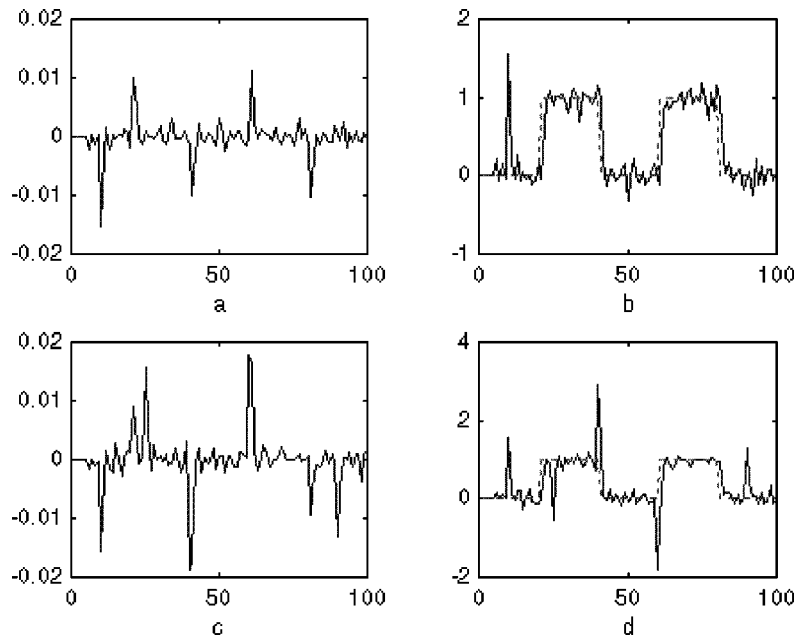

Fig. 5. Signals of the closed-loop system (50) in the presence of one outlier (*a, b*) and in the presence of five outliers (*c, d*) in an additive correlated noise on the output. Other values and markings are the same as in Fig. 4.

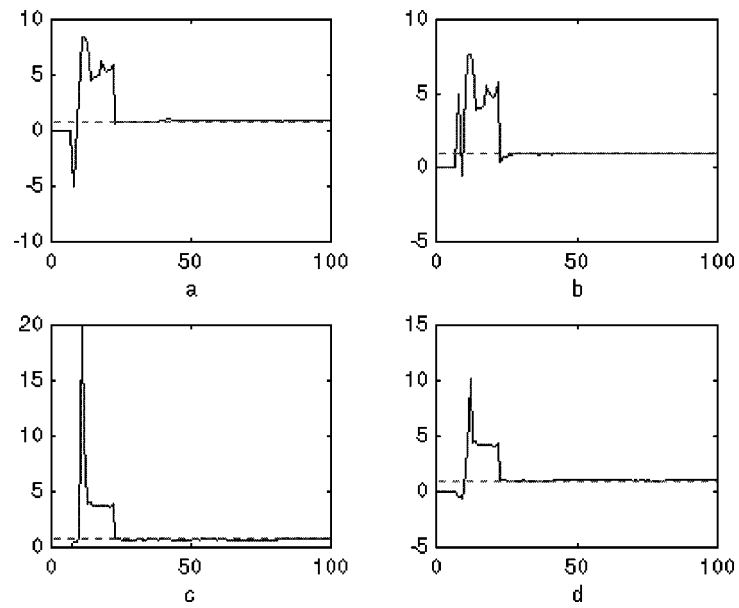

Fig. 6. Dependence of current estimates of the parameters of the closed-loop system on the number of recursive iterations:  $x$ -axis – numbers of iterations,  $y$ -axis – meanings of estimates.  $a, c$  – estimates of the coefficient of the nominator of the system transfer function,  $b, d$  – estimates of the coefficient of the denominator of the system transfer function. Dotted lines correspond to exact values of estimated parameters. The estimates are obtained by the ordinary RLS: ( $a, b$ ) using the observations of the input (Fig. 4c) and the output (Fig. 4d), ( $c, d$ ) using the respective observations, shown in Fig. 5a, b.

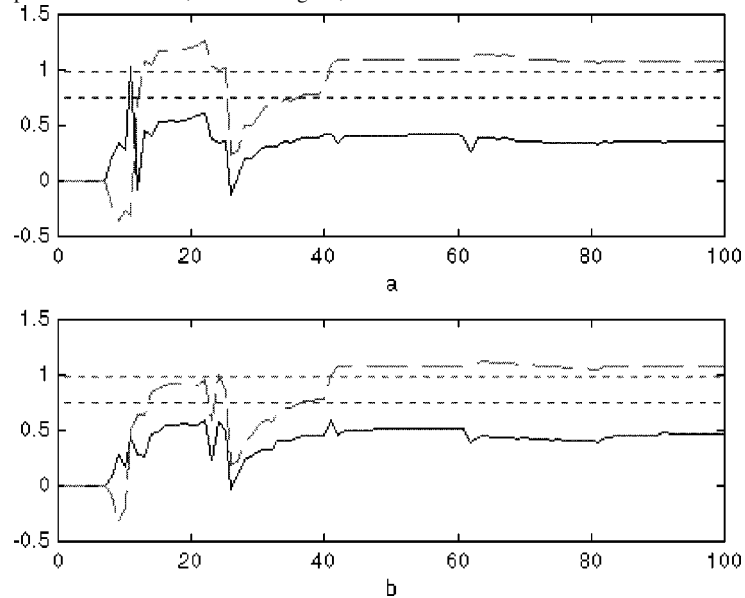

Fig. 7. Dependence of current estimates (solid and dashed lines) of the parameters of the closed loop system on the number of recursive iterations: a) estimates are calculated using observations of the input (Fig. 5c) and the output (Fig. 5d) and the ordinary RLS, b) using the robust  $M$ -algorithm. Other values and markings are the same as in Fig. 6.

We calculate the estimates of parameters  $a = -0.985$ ;  $b = .75$  of system (50) by processing observations  $y(k)$  and  $u(k)$  using the ordinary RLS and the  $H$ -technique (57)–(63), which is suited for the system, described by the difference equation (50). In Figs. 4, 5 simulated input, noisy output and reference signals of the closed-loop system (Fig. 3), are shown. Fig. 4 corresponds to the case where there are no outliers in the correlated noise  $v(k)$ ,  $k = 0, 1, 2, \dots$  at all. On the other hand, the respective inputs and outputs in the presence of outliers in observations used for their estimation are shown in Fig. 5. The parameter estimation results are presented in Figs. 6, 7. It follows that the accuracy of estimates is lower, when there appears an additive noise even with one isolated outlier (Fig. 6c, d) as compared to the case where there is no outlier in observations (Fig. 6a, b). The estimation results for the case of five outliers (Fig. 5c, d) in observations to be processed are shown in Fig. 7: using the ordinary RLS (7a) and the  $H$ -technique (7b). It should be noted that the accuracy of estimates (solid and dashed lines) obtained by the  $H$ -technique (Fig. 7b) is higher than that of estimates calculated by the ordinary RLS (Fig. 7a). Such an accuracy can be increased if the generalized RLS and respective robust analogous techniques could be used.

## 8. Conclusions

Outliers in observations to be processed strongly influence the quality of the performance of a closed-loop system. For the estimation of parameters of such a system, the direct approach that ignores the feedback and identifies the open-loop system using only input-output observations, and robust  $H$ -technique calculating  $M$ -estimates applying Huber's  $\psi\{\cdot\}$  function could be used. In such a case the accuracy of estimates is increased in comparison with the estimates obtained by the ordinary RLS.

## References

- Åström, K.J. (1987). Adaptive feedback control. *Proc. of the IEEE*, **75**(2), 185–217.
- Forsell, U., and L. Ljung (1999). Closed-loop identification revisited. *Automatica*, **35**, 1215–1241.
- Isermann, R. (1982). Parameter adaptive control algorithms – a tutorial. *Automatica*, **18**(5), 513–528.
- Halwass, M. (1988). Selbsteinstellende LQG-Regelung. *MSR*. Teil 1, **1**, 2–6.
- Halwass, M. (1988). Selbsteinstellende LQG-Regelung. *MSR*. Teil 2, **2**, 61–63.
- Huber, P.J. (1964). Robust estimation of a location parameter. *Ann. Math. Statist.*, **35**, 73–101.
- Huber, P.J. (1972). Robust Statistics. A review. *Ann. Math. Statist.*, **1**, 799–821.
- Huber, P.J. (1981). *Robust Statistics*. J. Wiley. New York.
- Novovičova, J. (1987). Recursive computation of  $M$ -estimates for the parameters of the linear dynamical systems. *Problems of Control and Information Theory*, **16**(1), 4–59.
- Polyak, B.T., and Ya.Z. Tsympkin (1980). Robust identification. *Automatica*, **16**(1), 53–65.
- Pupeikis, R. (1994). On-line estimation of dynamic systems parameters in the presence of outliers in observations. *Informatica*, **5**(1–2), 189–210.
- Pupeikis, R. (1998). State estimation of dynamic systems in the presence of time-varying outliers in observations. *Informatica*, **9**(3), 325–342.
- Pupeikis, R., and P.J. Huber (1997). Adaptiv-robuste Zustandsschätzung mit Optimierung des Schätzprozesses. *Bericht zur Deutsche Forschung Gemeinschaft Projekt "Echtzeit-Optimierung grösser Systeme"*.

**R. Pupeikis** received Ph.D. degree from the Kaunas Polytechnic Institute, Kaunas, Lithuania, 1979. He is a senior researcher at the Process Recognition Department of the Institute of Mathematics and Informatics. His research interest include the classical and robust approaches of dynamic system identification as well technological process control.

## **Uždaro ciklo sistemų patvarusis identifikavimas, taikant tiesioginį metodą**

Rimantas PUPEIKIS

Straipsnyje adityviojo triukšmo su dideliais retais nuokrypiais atveju plėtojamas tiesioginis metodas, kuris taikomas uždaro ciklo diskretinio laiko dinaminių sistemų identifikavimui. Nežinomų parametrų  $M$ -įverčiams gauti, apdorojant įėjimo ir užtriukšminto išėjimo stebėjimus, pasiūlytas ir modeliuojant kompiuteriu ištirtas patvarusis  $H$ -algoritmas. Pateiktos patvariųjų įverčių kovariacijų matricių išraiškos. Gauti dinaminės sistemos parametrų skaičiavimų rezultatai, taikant du rekurentinius algoritmus: mažiausiųjų kvadratų ir  $H$ -algoritmą su Huberio funkcija.